



Picket Fence Installation Instructions

STRAIGHT PICKET #30040



SCALLOPED PICKET #30060

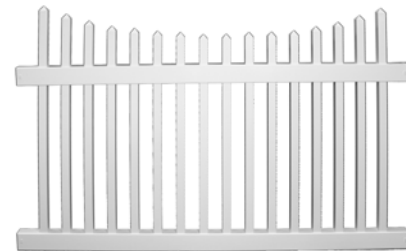

Box Contents

1 Top Rail (has channel openings through both sides, small for the top and larger openings for the bottom side to insert the pickets easier)
 1 Bottom Rail (has channels through one side)
 16 Straight Pickets with Caps
 1 Gothic Cap

1 Top Rail (has channel openings through both sides, small for the top and larger openings for the bottom side to insert the pickets easier)
 1 Bottom Rail (has channels through one side)
 16 Scalloped Pickets with Caps
 1 Gothic Cap

Solid Post

NOTE: Other parts options needed but not included are:
 Posts 4" x 4" x 6'.
 Posts come pre-cut to accept the top and bottom rails.

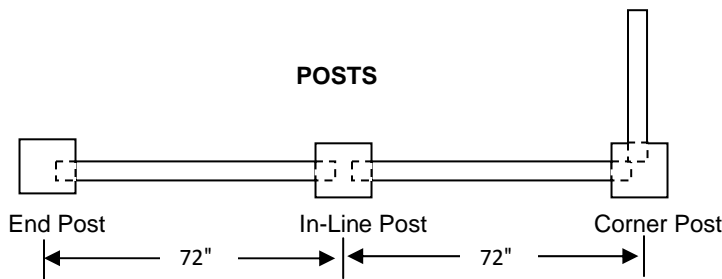

Layout Diagram

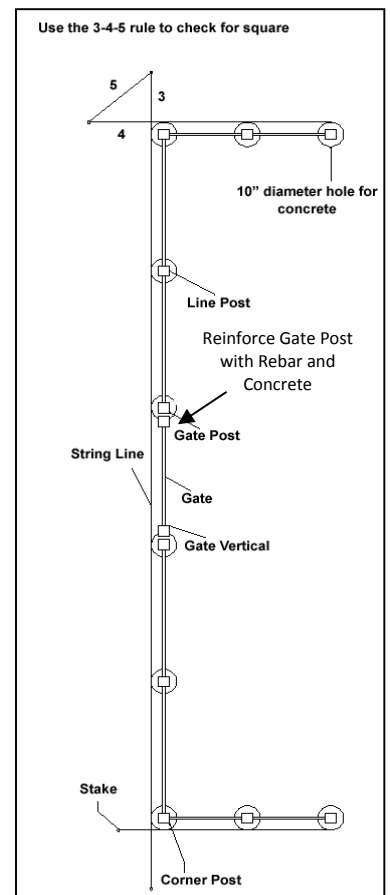

CODE INFORMATION



It is the installer's responsibility to follow all local codes, safety requirements, and file all necessary permits with the building inspector's office prior to installing the product. AmeraFence shall not be held liable for improper or unsafe installations.

Safety:

- Determine property lines.
- Review local building codes.
- Call utility company to mark lines before you start digging.

LAYOUT FENCE

- ✓ With stakes and line, layout the perimeter of the fence and check to make sure the layout is square using 3' - 4' - 5' rule. **(See Layout Diagram)**
- ✓ Locate and mark center of the posts 72" from center to center with stakes or paint.
- ✓ Gate posts should be located 48" apart from the inside edge of posts.



SET POST

- ✓ Dig post holes 30" to 36" deep depending on frost line and backfill with 6" - 12" crushed stone.
- ✓ Dig post holes 10" in diameter for 5" posts and 8" in diameter for 4" posts.
- ✓ Start with end or corner posts and gate posts. Determine fence post height and make sure the cutout for bottom rail is 2" or less above the grade.
- ✓ Set post in center of hole, then backfill with 4" to 6" of fine crushed gravel. Tamp around post to secure.
- ✓ Plumb post with level and measure from your guide line to check for alignments that post are 72" on center apart.
- ✓ String a line from the top of posts to provide height guide and set the remaining posts.
- ✓ With all posts in place double check alignment location, levelness, and height.
- ✓ Fill with concrete around posts up to 2" below the grade and tamp to eliminate any air pockets securing posts.
- ✓ Re-check posts and allow adequate time for concrete to cure.

Install Bottom Rails

- ✓ Slide 2" x 3½" bottom rails  into bottom rail post slots. Slide rail far enough into post to allow opposite end to be inserted in adjoining post. Complete this process around your fence perimeter.
- ✓ If ground is sloped, post slots may need to be modified on the top and bottom using a fine blade saw.

Install Pickets

- ✓ Install pickets into cut channels on bottom rail and snap into place.

Install Top Rail

- ✓ Install Top Rail over pickets. The openings on the top rail are larger on the bottom side of the rail for easier insertion and smaller on the top rail for a snug fit. Note: Top rail will slide up and down over pickets until snapped into post.
- ✓ Insert one end of top rail into post, slide in deep enough to allow 2nd end to slide into 2nd end post.

Post Caps

- ✓ Clean the top of posts and inside of post caps with a damp towel. Apply adhesive to the inside of post cap where it contacts the post.

Clean Up

- ✓ Clean up dirt marks with a mild soap and water.

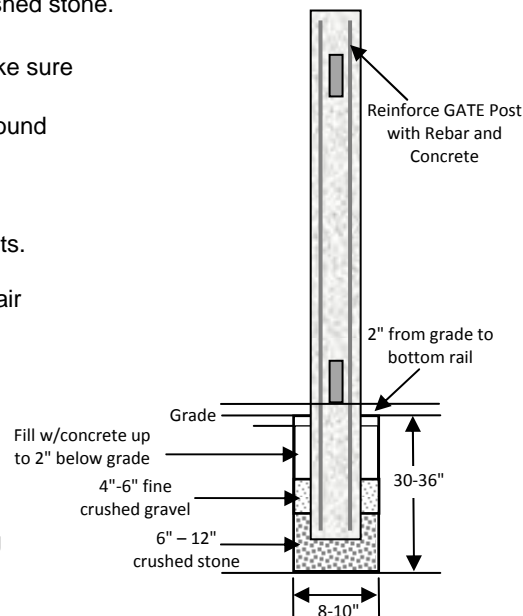

We appreciate your business and thank you for selecting **Amerafence**. If you have any questions or suggestions, please feel free to contact us at 877.788.1828 or visit us online @ www.amerafence.com.